

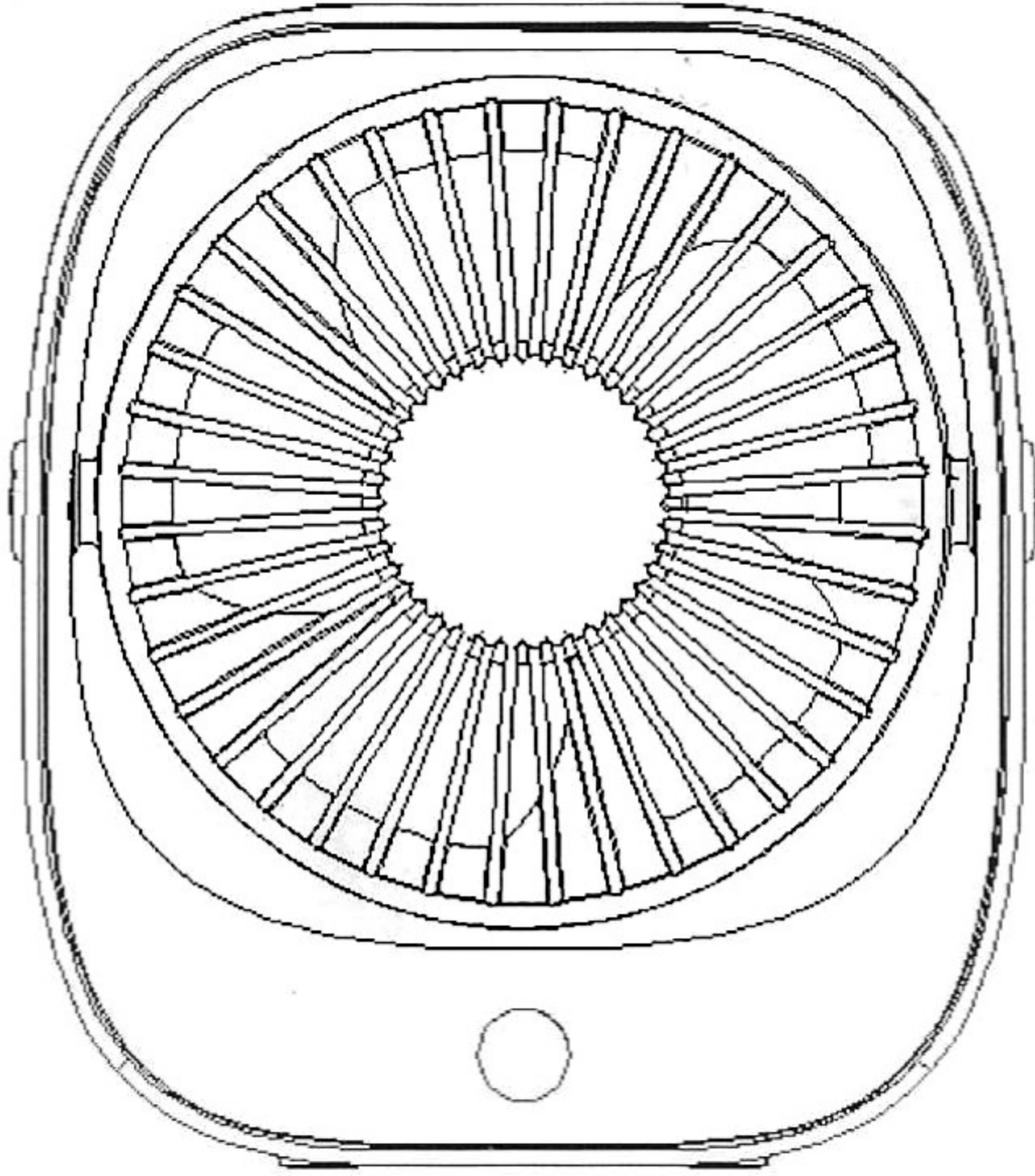

Rechargeable Fan

User Manual

Model No.: FL-804(FL-804B, FL-804W, FL-804D, FL-804T)



PLEASE SAVE THESE INSTRUCTIONS

WARNING: READ THIS OWNER'S MANUAL CAREFULLY BEFORE USE.

Product Specifications:

Input: DC 5 Volts – 1 Amp

Speed Level: 3 Speeds –High / Medium / Low

Working hours: Average 4- 5 hours at high speed

Battery capacity: 3,200 mAh

Hours of charging: 4-6 hours

Product dimension: 5.7"H × 5"W × 1.8"D

Product weight: 8.3 oz.

Remarks: Working hours and charging hours will differ based on different product

Product diagram

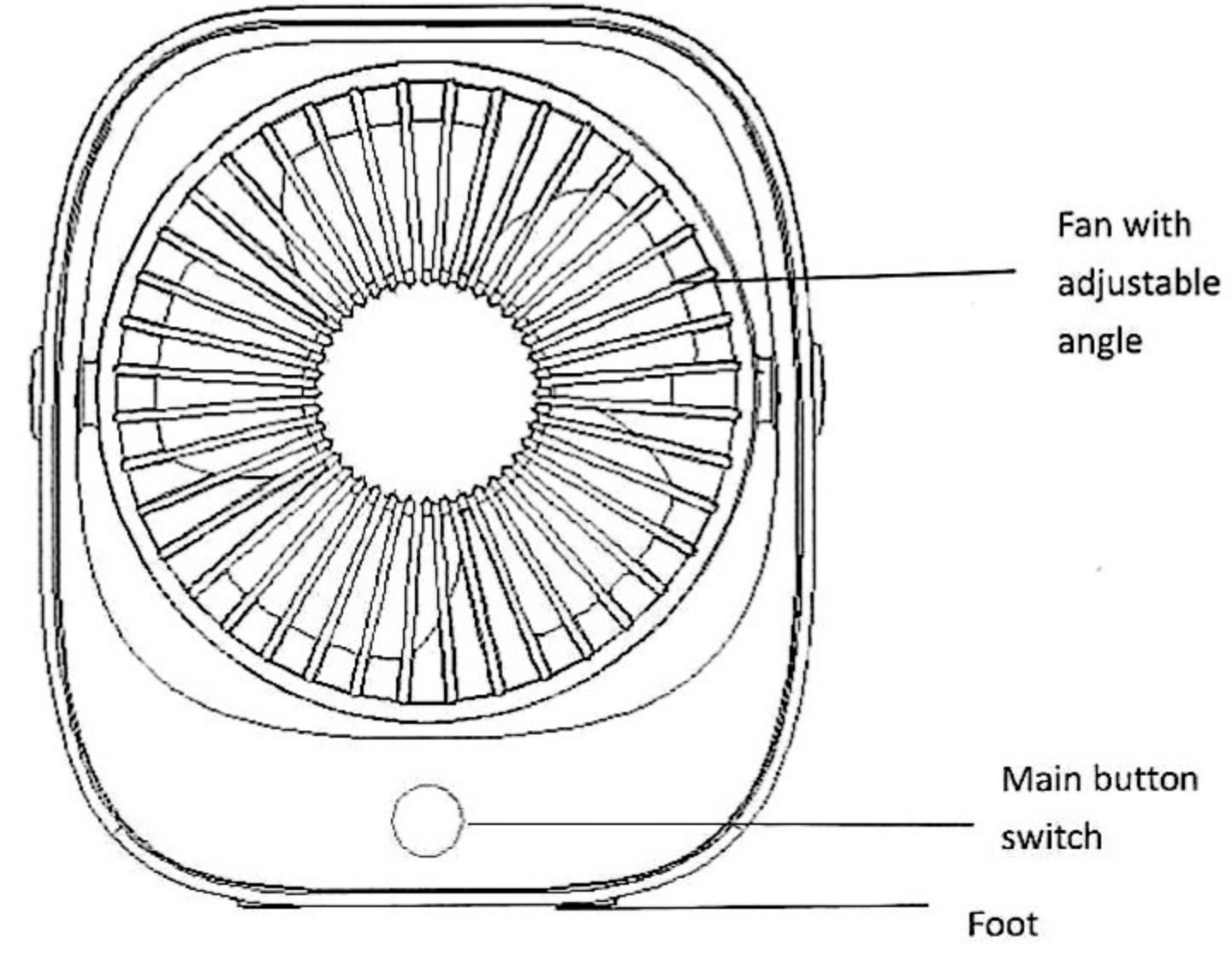

(Front view)

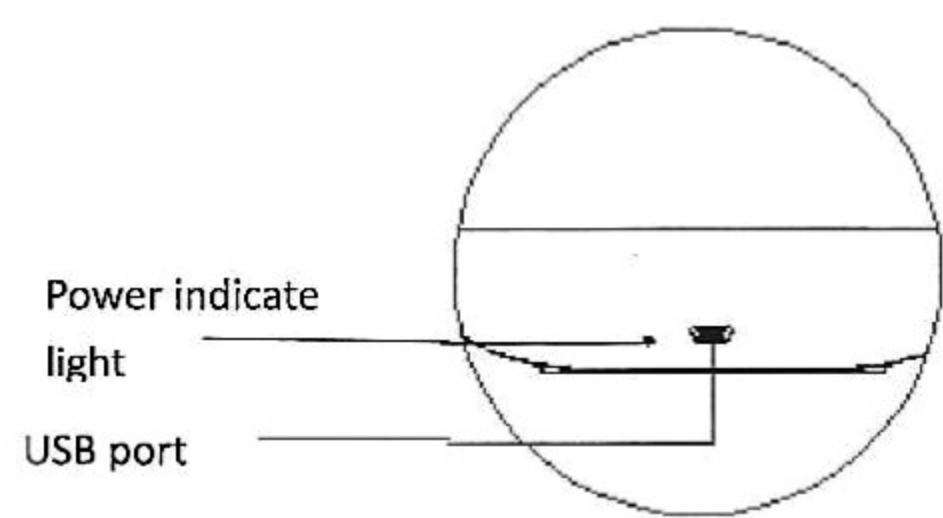

(Back view)

You can adjust the fan head angle from 10° to 40° as your want.

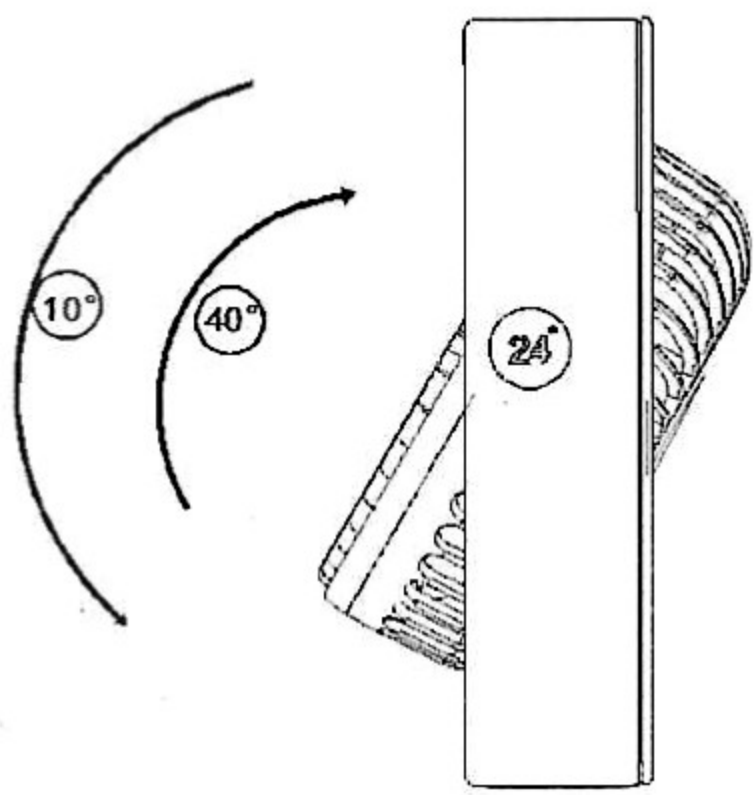

Charging Status

1. Connect the fan with power through USB cable
2. A RED LED light represents charging status
3. When the LED light turns BLUE, it is fully charged
4. When the fan is in use status, the LED light will turn BLUE color.

Operating the Fan

1. Push power button once, and the fan starts operating at its highest speed
2. Push power button a second time, and the fan operates at its medium speed
3. Push power button a third time, and the fan operates at its lowest speed
4. Push power button a fourth time, and the fan will turn off.

Working hours - when fully charged

At the lowest fan speed, the fan works for about 9-10 hours

At the middle fan speed, the fan works for about 7-8hours

At the highest fan speed, the fan works for about 4-5 hours

Warning:

1. Don't disassemble the product by yourself
2. Don't put the product in wet place
3. Don't put the product near hot place
4. Don't put the product near any liquid
5. Children should be supervised by adults when using

Cleaning and Maintenance :

1. Make sure the fan is off. Open the front grill at clockwise direction, take the front grill off. Please refer to below picture 1

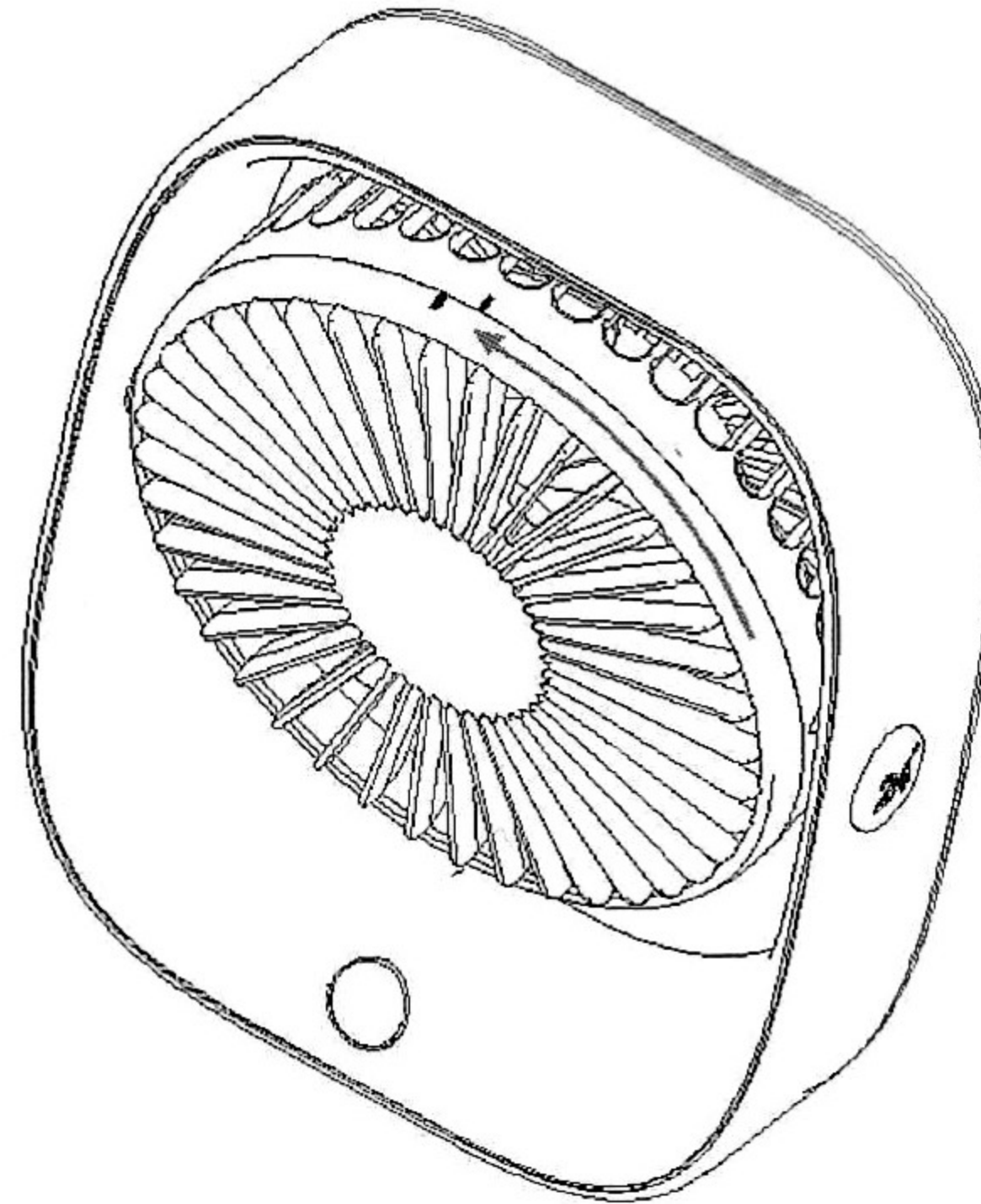

(Picture 1)

2. Clean the front grill and blade with soft cloth, refer to picture 2.

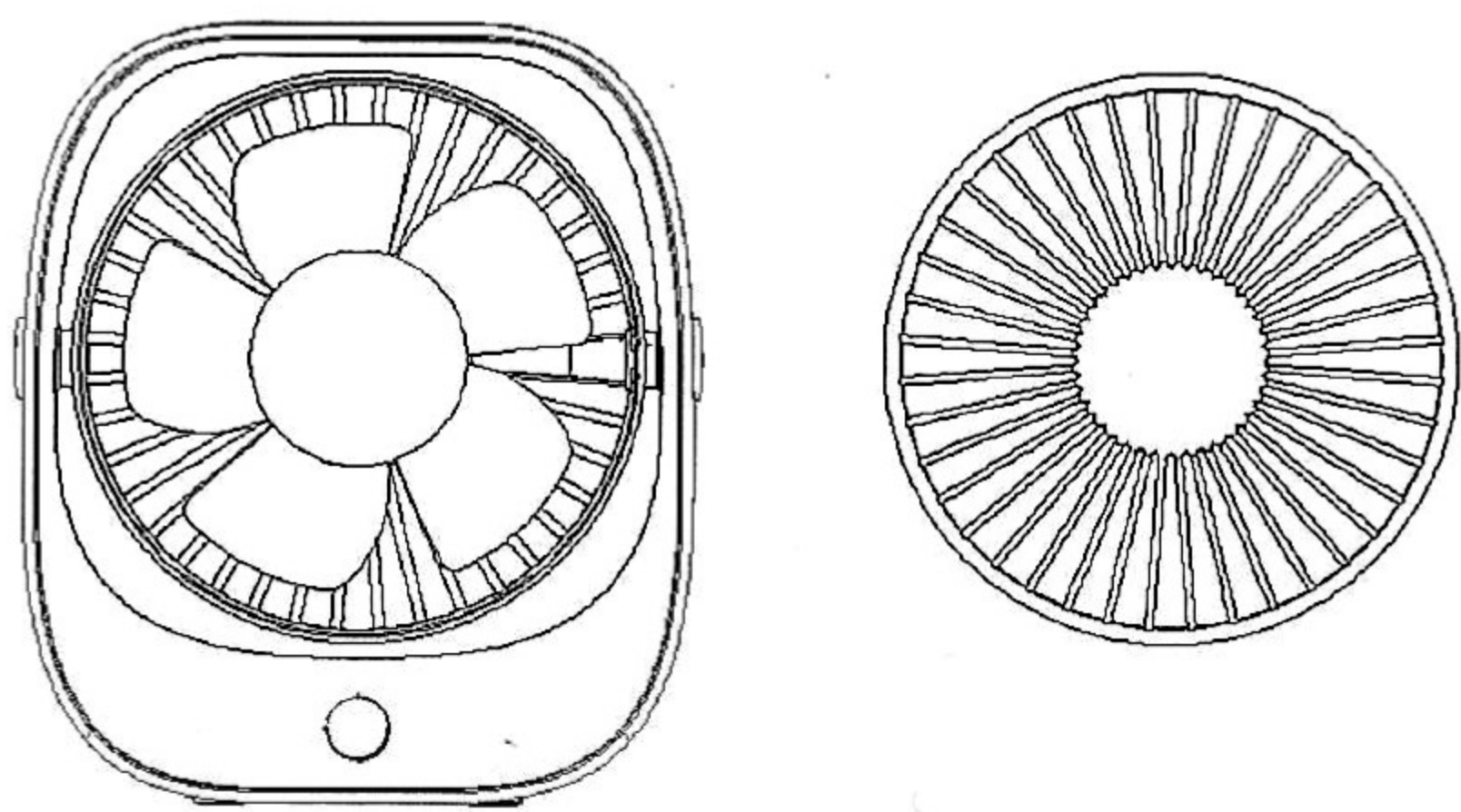

(Picture 2)

3. After washing, follow at anti-clockwise direction to assemble the front grill back.
Please refer to below picture 3

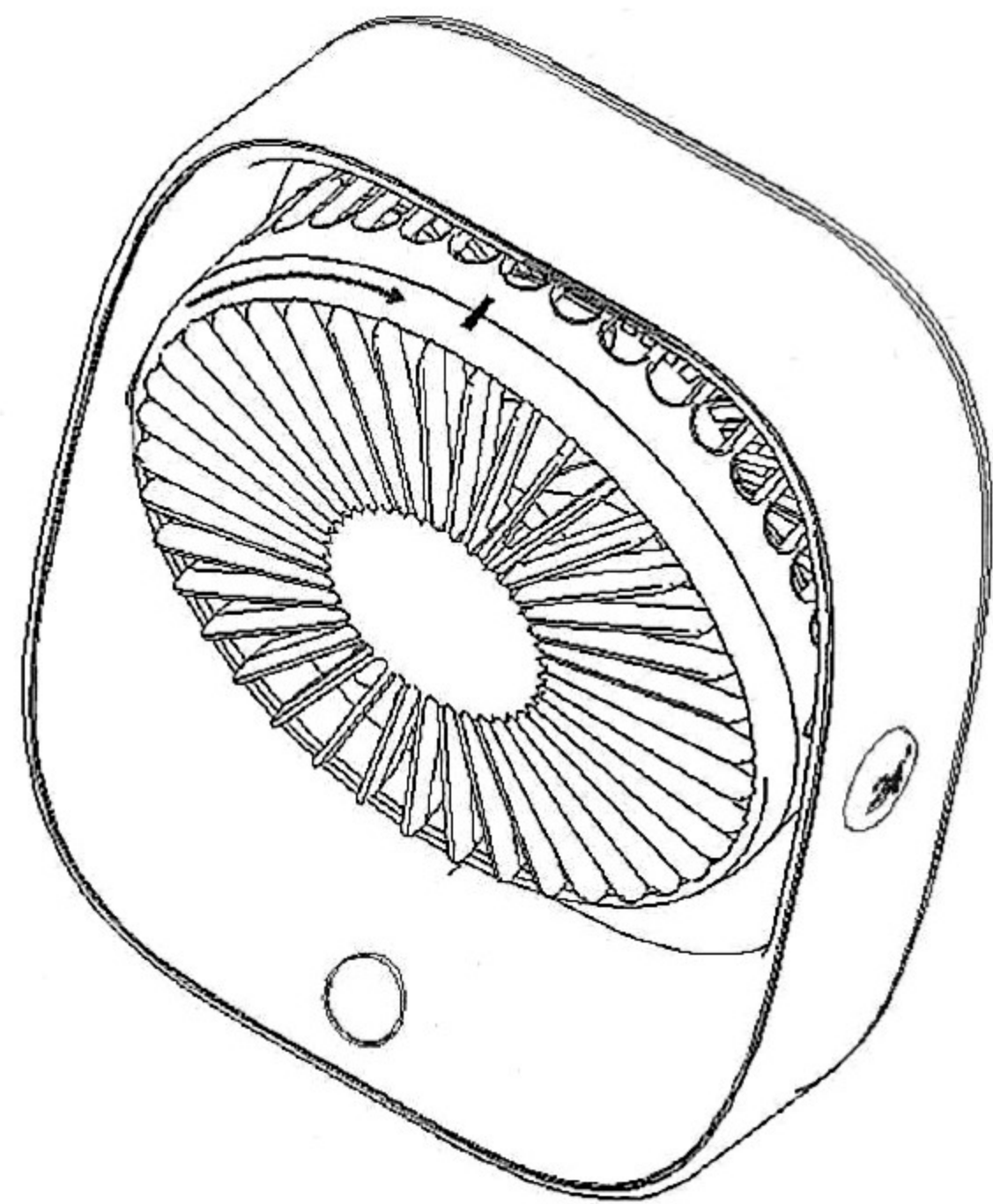

(Picture 3)

Special Attention:

1. When operating, the fan blade revolves at a high speed. Please don't put a finger or other objects in the fan blades.
2. Please don't use the fan in humid and wet weather or wet environment, at it could cause the product damage or to malfunction.
3. Please charge the fan with standard DC 5V voltage. Remove the USB cable when charging is completed.
4. Don't place the fan on flammables when charging.
5. If the fan gets too hot or out of shape, or if the battery is leaking while charging, please stop charging immediately.
6. Please keep the product at 32°F-104°F degrees Fahrenheit.
7. Please don't place the product in a fire, otherwise the battery will explode.
8. Please don't hit or smash the product. Repeated hitting may damage the product.
9. Please don't dismantle, change or repair the product by yourself.
10. Please don't replace battery by yourself, and replace followed by professional guidance.

What's in the box

- Fan - *1
- USB Cable - *1
- User Manual - *1
- ***

Customer Service and Support

To Obtain Warranty Support or Advice, Please Complete These Easy Steps:



Contact Mainstays PRODUCTS Technical Support

Phone: 1-866-321-9509

E-mail: Service@konwinchina.com

Monday – Friday 8 am - 5 pm CST

You will need to provide the unit's model number, serial number (**located on the heater's front panel, rear panel, or on the box**), date of purchase, retailer of purchase, a daytime phone number, and possibly a copy of your receipt.



Be Patient, Clear, and Concise.

Describe the issue and symptoms you have for, and about the product. A certified Mainstays Technical Support agent will give you an evaluation of your issue and your resolution options. If the answer is not available at that time, you will be referred to the appropriate channels, or given a call back within 72 hours with an answer or resolution.



If after speaking with Mainstays Technical Support, it is determined by one of our agents that your unit may need to be sent in to us to be evaluated/repared, our representative will provide you with a **reference number** and provide you with details on how to send in your unit for repair.

STOP!

In the unlikely event that you have a problem or question about your unit, please contact our Mainstays Customer Care Center.

We are always happy to help!

Call toll free: 1-866-321-9509

Monday - Friday 8 am - 5 pm CST

¡Atención!

En el improbable caso de que tenga algún problema o pregunta sobre el producto,

por favor póngase en contacto con nuestro Centro de Servicio al Cliente Mainstays.

¡Siempre estamos felices de ayudar!

Teléfono sin cargo: 1-866-321-9509

De lunes a viernes: 8 am- 5pm CST